

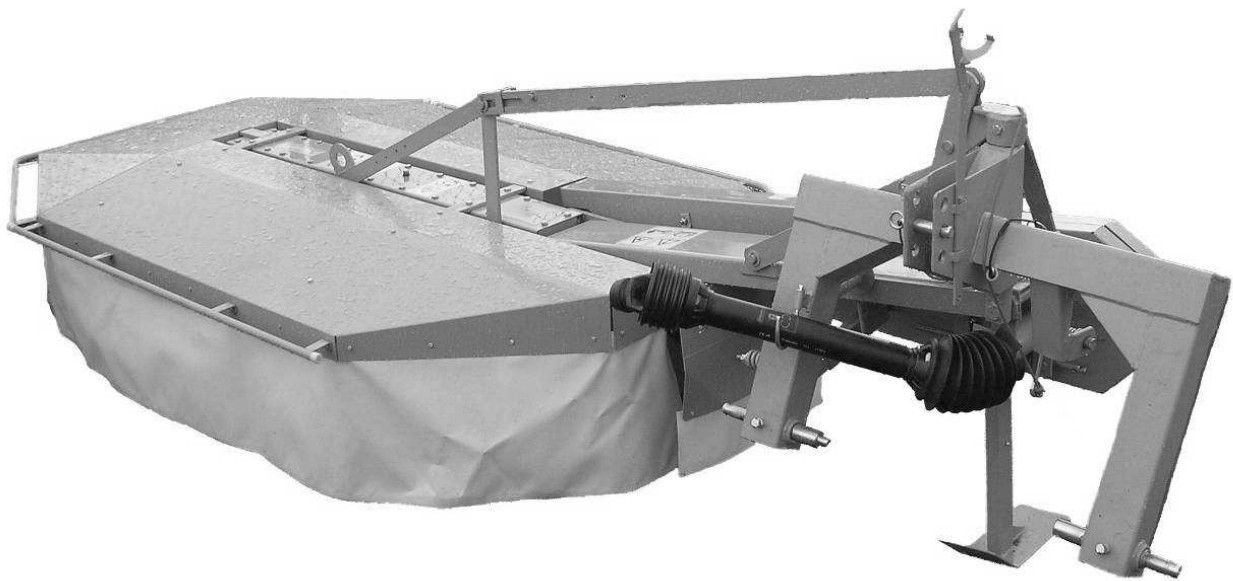

OPERATOR'S MANUAL



REAR DRUM MOWER

Z 010 (H) – 5'5"
Z 010/1 (H) – 6'1"
Z 010/2 (H) – 6'11"
Z 010/4 – 6'11"

Serial No:

IN005USA011
2015.10.29
EDITION NO 11

The original instruction



DANGER
DO NOT TURN THE DRIVE ON
IF THE MOWER IS **NOT** IN
WORKING POSITION



DANGER
DO NOT LIFT THE MOWER IF
MOWING DISCS HAVE NOT
COME TO COMPLETE
STANDSTILL



DANGER
DO NOT OPERATE WHEN
ANY PERSON REMAINS IN
THE DANGER AREA OF 164'

ADJUSTING THE MOWER FOR MOWING

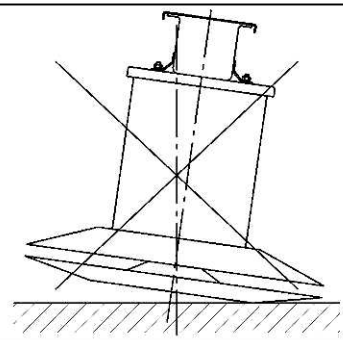
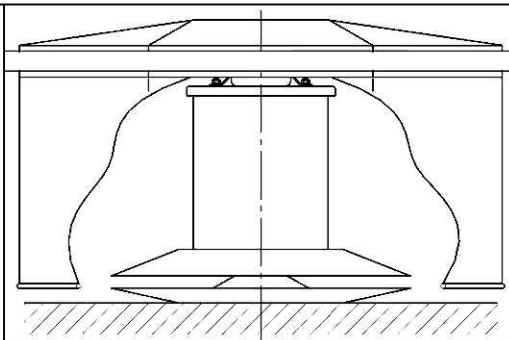
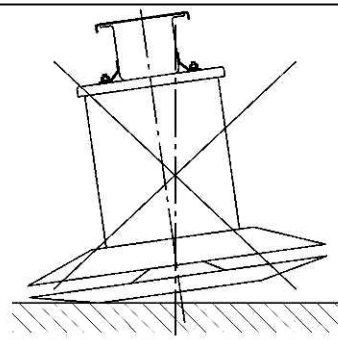

WARNING!
Keep this manual for further reference.

Comprehensively tested construction and proper choice of materials ensure high reliability and durability of our products.

Contents	Page
1. IDENTIFYING THE MACHINE.....	2
2. INTRODUCTION	2
3. TECHNICAL DATA.....	3
3.1. Specifications	3
3.2. Design and working principle	4
3.3. Standard equipment and spare parts.....	4
4. SAFETY PRECAUTIONS	6
4.1. General safety rules and regulations	6
4.2. Conditions of mounting mower on tractor	8
4.3. Transport	8
4.3.1. Putting the mower onto another vehicle for transport	8
4.4. Working parts.....	9
4.5. PTO shaft	10
4.6. Residual risk.....	10
4.7. Safety labels and their meaning	11
4.8. Design and operation of safety breakaway device.....	13
5. OPERATION.....	15
5.1. Attaching the mower to the tractor	15
5.2. Preparing the mower for transport	16
5.2.1. Standard mower design	16
5.2.2. Mower design with hydraulic lifting (optional equipment)	17
5.2.3. Mechanical lock of hydraulic lifting	18
5.3. Preparing the mower for transport on public roads.....	18
5.4. Mounting PTO shaft.....	18
5.5. Adjusting conditioner shaft's position	20
5.6. Replacing flails in conditioner's shaft	20
5.7. Operation.....	21
5.7.1. Standard mower design	21
5.7.2. Mower design with hydraulic lifting (optional equipment)	21
5.8. Dismounting mower from tractor	22
6. MOUNTING AND ADJUSTMENTS.....	22
6.1. Mounting and timing of the knives	22
6.2. Replacing the knives	22
6.3. Adjusting the cutting unit.....	23
6.4. Adjusting the cutting height.....	23
6.5. 3-point linkage support chain.....	24
6.6. Maintenance and service	24
6.6.1. Checking the knives and knife holders.....	24
6.6.2. Checking V-belts tension	25
6.6.3. Daily maintenance	25
6.6.4. After-season maintenance and storing of machine.....	26
6.6.5. Restarting the machine after repairs or longer storing periods.....	26
7. LUBRICATION INSTRUCTION	27
7.1. Gear trough (gearbox)	27
7.2. Mower's gearbox and conditioner's intersecting axis gear.....	27
7.3. Risks present when lubricating	27
8. DEFECTS AND THEIR REPAIRS.....	28
9. DISASSEMBLY AND WITHDRAWAL FROM USE	29
9.1. Scrapping	29
10. WARRANTY CARD	29
11. WARRANTY TERMS	29
11.1. Warranty claims procedures.....	29
11.2. Warranty repairs record.....	31

1. IDENTIFYING THE MACHINE

Data plate is mounted to the mower's main frame in the place shown below (Fig. 1).

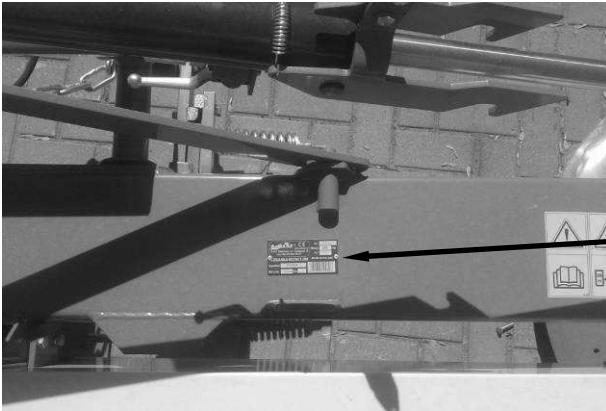

Fig. 1. Data plate location



Fig. 2. Data plate

Data plate includes:

- name of the manufacturer,
- mower's serial number,
- mower's type,
- manufacturing date,
- version number,
- weight,
- quality management sign,
- CE mark,
- MADE IN POLAND sign,
- barcode.

2. INTRODUCTION

- ❑ This operator's manual is essential for safe and proper use of this mower and should be read before anyone operates this mower. It should be kept near the mower for future use. If the mower is used by another operator, it should be in working condition and include this operator's manual and all other basic equipment.
- ❑ Operator's manual is attached to every machine in order that the operator can familiarize himself with design, working principles, service and adjustment of the mower. The operator should be familiar with common safety rules and procedures.
- ❑ The mower is manufactured according to international safety rules.
- ❑ Compliance with the safety precautions in this operator's manual will help to enable safe operation.
- ❑ Please contact your dealer if you have any queries relating to the operation and service of the mower.

3. TECHNICAL DATA

Rotary suspended rear drum mower is designed for mowing and forming rows of: common grass, medick, etc on grasslands and on stone free fields. Grassland being mowed should be even, previously prepared by rolling and other treatment. In lifted rotary mower with swath conditioners, as a result of a difference in mowing speed, consequent layers of grass under the flails are subjected to the process of attrition of plant wax layer. It makes grass drying process simpler and faster by approx. 30 – 40 %.



WARNING:

Use of the mower for purposes other than described above is forbidden. Improper use can be dangerous and may lead to voiding of the warranty. Mower should be operated and repaired only by people familiar with its detailed specifications and with all applicable safety rules and regulations and with the relative dangers. Unauthorized modifications to the mower will lead to voiding the warranty.

3.1. Specifications

Tab. 1. Specification of rear drum mower

Model	Z 010 (H)	Z 010/1 (H)	Z 010/2 (H)	Z 010/4
Working width	5'5"	6'1"	6'11"	6'11"
Number of knives [pcs]	6 (2 x 3)	6 (2 x 3)	8 (2x4)	8 (2x4)
Tractor PTO rpm	540 rpm	540 rpm	540 rpm	540 rpm
Tractor power required	40 HP	60 HP	70 HP	from 75 HP
Working capacity	~ 1.5 ha/h	~ 2.0 ha/h	~ 2.5 ha/h	~ 2.5 ha/h
Transport length	8'2"	10'	11'10"	11'10"
Transport width	5'1"	5'2"	5'8"	5'12"
Working width	10'4"	10'11"	12'11"	12'11"
Conditioner's working width	-	-	-	2'4"
Weight	881.85 lbs (903.90 lbs)	1003.90 lbs (1014.13 lbs)	1223.57 lbs (1234.59 lbs)	1521.19 lbs
Noise level L_{pA}	80 ± 1 dB			
L_{Amax}	82 ± 1 dB			
L_{Cpeak}	114 ± 1 dB			
PTO shaft requirement	400 Nm	400 Nm	540 Nm*	540 Nm *
Conditioner's PTO shaft	-	-	-	250 Nm
No. of flails [pcs]	-	-	-	36
Conditioner's shaft revolutions	-	-	-	630 rpm
Cutting speed of the knife	90 m/s	88.3 m/s	90.2 m/s	90.2 m/s
Drum revolutions	2046 rpm	1813 rpm	1610 rpm	1610 rpm
3-point linkage category	I – II	II	II	II
*with overrunning clutch				

L_{pA} – noise level related to 8 hour working time. Acoustic pressure level corrected by frequency characteristic A, averaged in time.

L_{Amax} – maximum value corrected by frequency characteristic A of acoustic pressure level.

L_{Cpeak} – peak level of acoustic pressure corrected by frequency characteristic C.

3.2. Design and working principle

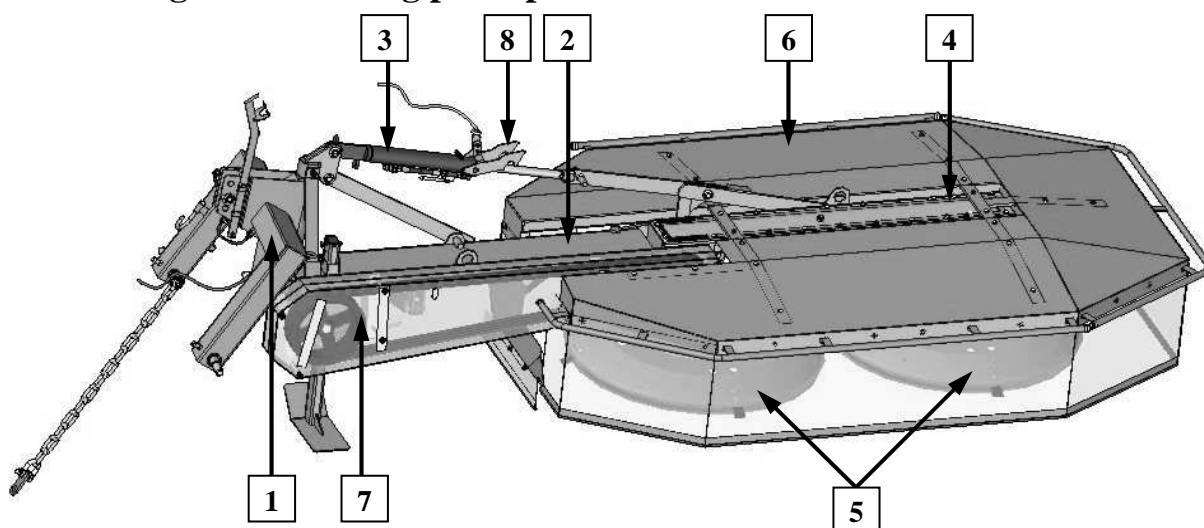

Fig. 2. Parts of SaMASZ rear drum mower – flat cover

- | | |
|---|----------------------|
| 1 – 3-point-linkage frame, | 5 – cutting unit, |
| 2 – middle bar, | 6 – cover guard, |
| 3 – hydraulic cylinder – extra equipment, | 7 – drive unit, |
| 4 – main frame and gearbox, | 8 – mechanical lock. |

Mower with swath conditioner comprises the following components (**Fig. 3**):

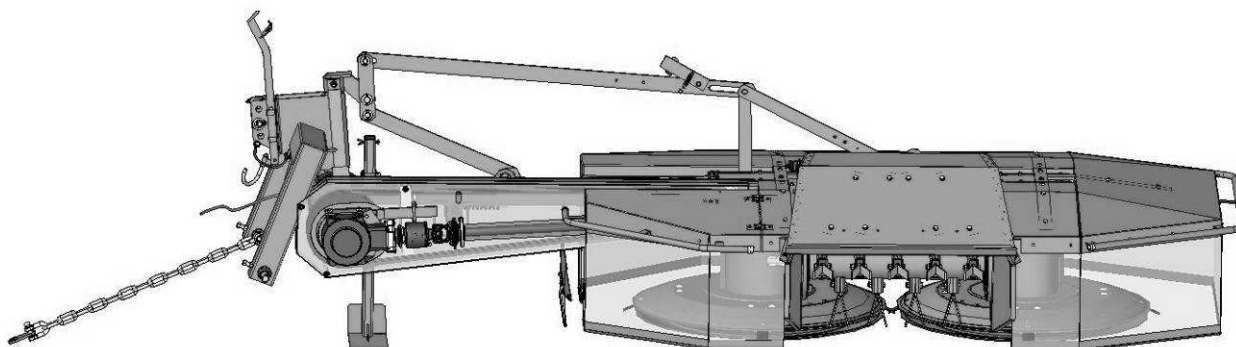

Fig. 3. Mower with swath conditioner

- | | |
|--------------------------------|--------------------------------|
| 1 – conditioner's shaft, | 4 – working drum guard, |
| 2 – conditioner's gearbox, | 5 – conditioner's upper guard. |
| 3 – conditioner's drive shaft, | |

3.3. Standard equipment and spare parts

The mowers are sold with the following standard equipment:

- warranty card,
- operator's manual with spare parts list,
- cutting knives: 1 set,
- PTO shaft (**Tab. 2**),
- spray paint (150 ml).

Optional extra equipment:

- warning triangle.

Tab. 2. Recommended PTO shafts for SaMASZ rear drum mowers

Mower	Power HP	Length mm	Torque Nm	Symbol	Clutch	Manufacturer	Remarks
Z 010; Z 010/1	35	2'2"-2'11"	460	7G3N066CE007007MA		Bondioli & Pavesi	
Z 010/2	35	2'2"-2'11"	460	7G3N066CE007096MA	Overrunning right	Bondioli & Pavesi	
Z 010/4	35	2'2"-2'11"	620	7G5N066CE007096LA	Overrunning right	Bondioli & Pavesi	

Shaft end without clutch –
Connect to the tractor.

Shaft end without clutch –
Connect to the mower.

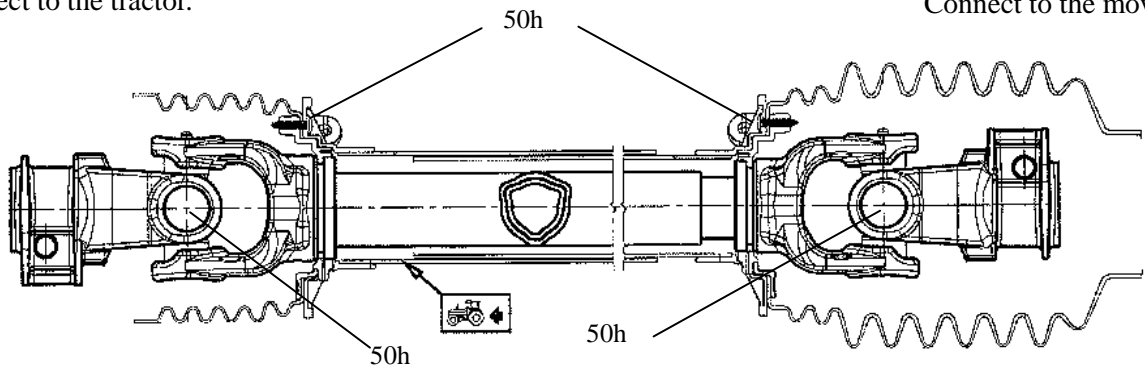

Fig. 4a. PTO shaft lubrication points. Mounting directions – Z 010 and Z 010/1

Shaft end without clutch –
Connect to the tractor.

Shaft end with right overrunning
clutch – Connect to the mower.

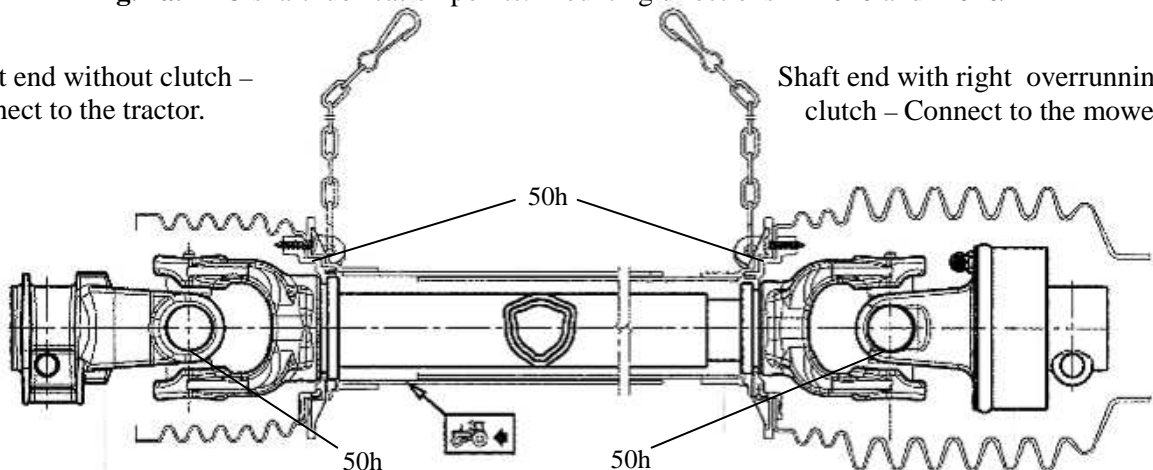

Fig. 4b. PTO shaft lubrication points. Mounting directions – Z 010/2 and Z 010/4

NOTE:

Lubricate the PTO shaft with high quality multi-purpose grease every 50 shaft operating hours (**Fig. 4**). If access holes are accessible, lubricate fittings through access holes.

PTO shafts of other brands with equivalent parameters could be used after first obtaining SaMASZ permission.

NOTE:

Before any operation read the on the mower's PTO shaft operator's manual carefully. In the event the PTO shaft is damaged due to its use for any other purpose than specified in the manual, the SaMASZ company will not accept any warranty claim. **Do not operate the clutch when overloaded for more than 10 seconds.**

NOTE:

Optional extra equipment should be ordered separately.

The mower is equipped with optional equipment such as holders and brackets used to mount warning lights and plates. Combined lights and reflectors are mounted on warning plates.

4. SAFETY PRECAUTIONS

 **WARNING** The following precautions are for your safety. They must be read carefully and followed by every person who operates or maintains the machine. Failure to follow these safety precautions could result in serious injury or death to the operator, maintenance person or bystanders and property damage to the machine and surrounding property.

Safety Signal Words

This manual and the safety labels attached to this equipment utilize signal words that signify safety hazards with different levels of severity. Below are the words used and the definitions for these words:

- **DANGER** indicates a hazardous situation which, if not avoided, will result in death or serious injury
- **WARNING** indicates a hazardous situation which, if not avoided, could result in death or serious injury
- **CAUTION** indicates a hazardous situation which, if not avoided, could result in minor or moderate injury
- **NOTICE** is used to address practices not related to physical injury

4.1. General safety rules and regulations



The following descriptions are for your safety: They must therefore be read carefully and applied every time you use the machine.

- The machine has been designed for use by one single operator.
- When using, servicing, repairing, moving or storing the machine, the operator must wear safety footwear, safety gloves plus ear protection and dust mask if necessary.
- During use, the machine may give rise to dust, especially if the soil is dry. You are advised to use a tractor with a cab fitted with filters in the ventilation system. Failing this, wear a dust mask with filter to protect your respiratory tract
- Front axis of the tractor should be weighted to keep the balance. If need be, use front wheel weights.
- In order to keep steering conditions, impact on front axis should be at least 20% of the complete tractor.
- Be extremely careful whenever using hydraulic lift lever or buttons. Any operation with hydraulic lift lever should be done from operator's seat; **DO NOT** move the lever from outside of a tractor.
- In case of tractors equipped with EHR, operating with hydraulic lift is done by the buttons mounted outside the tractor's cabin. When operating be extremely careful.
- When switching from mowing to transport position, remove the entire PTO shaft or at least one end of the shaft from the tractor's PTO so it cannot turn.
- When attaching the mower to a tractor, the operator should wear protective gloves.
- **DO NOT** operate the mower unless all safety guards are in place and operational. In addition, any damaged protective cover should be replaced with a new one

- ❑ Start mowing only when tractor's PTO reaches its normal 1000 rpm. DO NOT exceed 1050 PTO rpm.
- ❑ No person (except operator) should stand within danger area which is a minimum of 170' from any operating part, especially when operating near roads and in areas with stones and other debris. Be certain that children and animals are at a safe distance away from the machine.
- ❑ **IMPORTANT:** Maintenance and adjustment should ONLY be done after the following has occurred:
 - ❑ tractor's engine has been stopped and ignition key has been taken out,
 - ❑ all rotating parts have come to complete standstill (NOTE: cutting knives will rotate for several minutes after engine is turned off),
 - ❑ the cutting unit is on the ground, and
- ❑ Never tamper with or remove safety devices on the machine or make them inoperable.
- ❑ Before starting work and periodically thereafter, replace any damaged, missing and/or worn knives and knife holders.
- ❑ When driving on public roads always comply with local traffic regulations, especially those concerning warning lights.
- ❑ When the mower is lifted for repair on 3-point linkage, it should be secured against falling by mechanical support or by chain.
- ❑ The bolts and other fasteners have to be periodically checked and, if necessary, tightened or replaced. DO NOT work with damaged or worn fasteners.
- ❑ Never lift the mower on tractor linkage when the drive is operating and the cutting drums are rotating.
- ❑ When operating the mower, the tractor should always be equipped with operator protection that is required by laws and regulations.
- ❑ Never start the mower when the mower drums are off the ground.
- ❑ Before you start the tractor make sure that all drives are turned off and the levers that turn the hydraulics are in neutral position.
- ❑ Never leave tractor's engine running without supervision. Before you leave the tractor, turn off the engine and remove the key from the tractor's ignition.
- ❑ DO NOT operate the mower when driving the tractor backwards.
- ❑ Permissible inclination of the mower on a slope when working and during transport is 8°. If exceeded the mower may be tipped over.
- ❑ Never stand between tractor and mower if the tractor and the mower are not secured against moving with the tractor's brake.
- ❑ If any maintenance must be done under lifted mower, it must be blocked or otherwise secured against falling.
- ❑ When the parts of the mower need replacement, use original spare parts only as specified in the spare parts list. Pay particular attention to PTO shaft's guards and mower's and tractor's PTO shaft guards.
- ❑ Hydraulic hoses are potentially very dangerous. Do the following to minimize any hazards:
 - ❑ Hydraulic hoses should be periodically checked and if any damage to the hoses have occurred or if they have been used more than 5 years, replace with new ones.
 - ❑ Never use scotch tape to repair hydraulic hoses.
 - ❑ When connecting hydraulic hoses to tractor's hydraulic connectors, make sure that the tractor's or mower's hydraulic system is not under pressure.
- ❑ The mower should be stored under a roof so that it poses no hazard to both people or animals.
- ❑ In the event of an accident involving this mower in a field or on a road, follow all applicable first aid procedures and contact SaMASZ technical service.
- ❑ Mower should be kept clean, so as to avoid danger of fire.

4.2. Conditions of mounting mower on tractor

- ❑ Before mounting, be sure that the tractor and mower hitches are compatible and that the tractor's hitch load is adequate for the machine which is to be mounted or attached.
- ❑ Before mounting the machine, examine the technical condition of the mower's hitch assembly and tractor's 3-point linkage.
- ❑ Use only genuine cotter pins to mount the mower on a tractor.

4.3. Transport

The lifting, handling and transporting operations can be very dangerous unless they are carried out with the utmost caution. Have all persons not involved in the actual work move away from the area and limit the zone where the operations are to be carried out. Also make sure that the area in which the operations take place is clear and that there is a sufficient escape route, i.e. a free, safe zone to which the operators can quickly move if the load should fall.

The safety hooks and ropes used to lift the machine must be of an adequate carrying capacity

To minimize the risk of serious injury or death, do the following:

- ❑ When the machine is converted from the transport position to the work position and vice versa, you could be pinched or crushed by some of its parts. Take extra care when carrying out these maneuvers and have all persons keep well clear of the danger zone.
- ❑ Do not change position of the mower until there are no people or animals around (pay particular attention to children).
- ❑ While transporting the mower, put a warning plate with combined lights and reflectors and warning triangle on the mower.
- ❑ During transport, always put the mower in its proper and safe transport position. See section 5.3.
- ❑ Before putting the mower in transport position, make sure that the tractor's PTO is turned off and all rotating parts have come to a complete stop.
- ❑ Do not drive over 25 km/h (15 mph). Drive slower if road conditions are poor, especially on irregular surfaces or steep slopes.
- ❑ The behavior of the tractor on the road, such as its turning and braking capacities, are affected by the implements mounted.
- ❑ When driving on the road after work, check to make sure that the tires and soil working tools are clean to prevent the road surface from becoming dirty.

Make sure that the machine is not damaged during transport.

4.3.1. Putting the mower onto another vehicle for transport

The driver and the carrier are responsible for the mower's transport safety. Equipment and parts must be secured during transport. To put the mower onto another vehicle in a safe way, please follow the following rules.

- ❑ Transport should be done by qualified and specifically trained personnel,
- ❑ Grab the mower by any lifting devices only in places indicated by hook sign (**Fig. 5**),
- ❑ For mower lifting, use only lifting devices with hoisting capacity larger than mower's weight shown in data plate. This also applies to ropes and chains used for lifting,
- ❑ Do not lift if transport belts, belt suspensions, ropes are damaged. Whenever damage to these parts occurs, replace with new ones,
- ❑ When mounting slings, chains, handles etc., always set the machine's center of gravity properly,
- ❑ To safely support the machine, use ropes of adequate length so that the angle between them is no greater than 120°, and the angle between the strand and the vertical is no greater than 60°,

- ❑ Lift the machine with the utmost caution and move it slowly,
- ❑ No one should be within the range of action of the lifting equipment when any transporting operations are being carried out.
- ❑ Collapsible parts should be blocked in transport position,

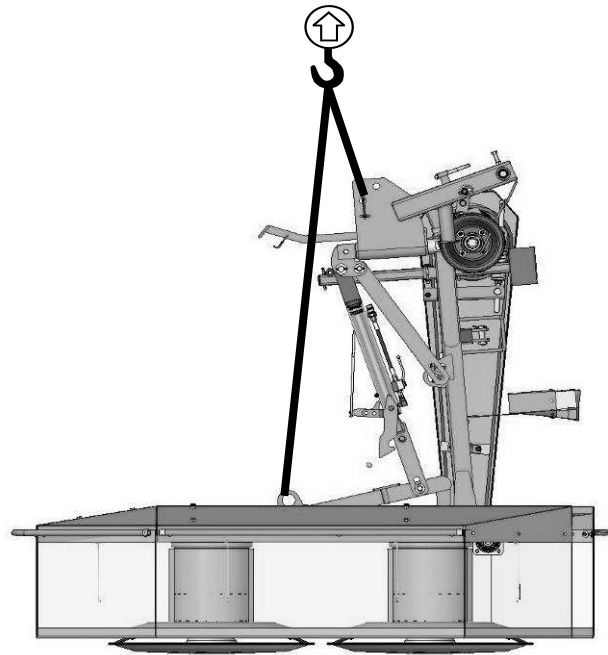

Fig. 5. Transport holders

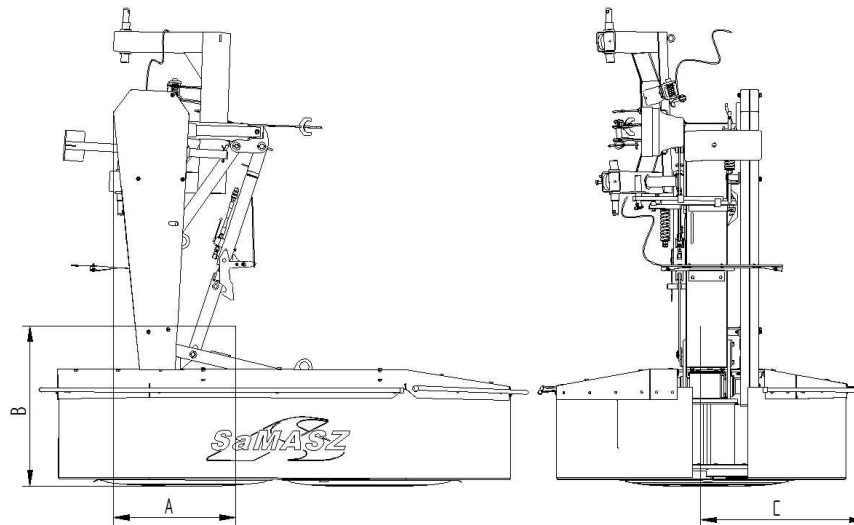

Fig. 6. Location of centre of gravity on rear drum mowers

Tab. 3. Location of centre of gravity

Dimension [ft, in]	Mower type		
	Z010 (H)	Z010/1 (H)	Z010/2 (H)
A	2'1"	2'2"	2'4"
B	2'5"	2'7"	2'8"
C	2'5"	2'8"	2'11"

4.4. Working parts

- ❑ Before operating the mower, check knife's and knife holder's condition.
- ❑ Worn or damaged knives or knife holders should be immediately replaced with new ones.

4.5. PTO shaft

- ❑ Before operating, read bar manufacturer's manual placed on the shaft. Follow all safety precautions in that manual.
- ❑ Use only PTO shafts recommended by mower's manufacturer with guards in good condition.
- ❑ In order to operate safely, use only undamaged PTO shafts and shields. Damaged PTO shafts and shields must be repaired or replaced with new ones before use.

4.6. Residual risk

Despite the fact that SaMASZ Białystok, the manufacturer of the mower, has taken great care in the design and manufacturing of the mower, certain risks during mower operation and maintenance are unavoidable. A major source of risk that could result in serious injury or death can occur during the performance of these operations.

Major source of risk follows performance of these operations:

- ❑ operation of mower by minors,
 - ❑ operation by individuals who have not read the operator's manual and safety labels,
 - ❑ operation of mower by persons under influence of alcohol or other substances,
 - ❑ not being cautious during transportation and moving mower during operation,
 - ❑ transport of persons who are on the machine,
 - ❑ presence of persons and animals within the mower operation range,
- performing servicing and machine adjustments with the engine on.

1. Danger of machine entanglement

This risk occurs when (1) changing position of a mower, (2) operating near rotating parts, and (3) working without safety guards. During operation, maintenance and adjustment, always wear protective gloves, shoes and clothes without loose parts, belts and so on. Always comply with safety labels placed on the mower.

2. Danger of cutting injury

This risk occurs during replacement of working parts with sharp edges. During any maintenance work, always use safety gloves.

3. Danger of injury from liquid ejection out of hydraulic system

During connection of hydraulic hoses to hydraulic connectors, be sure that tractor's or mower's hydraulic system is not under pressure. Regularly check hydraulic hoses for leaks.

4. Forbidden actions

During mower's operation, do not do the following:

- ❑ never unblock the mower, make any regulations or repairs of the mower while it is in motion,
- ❑ never change order of operation and maintenance activities described in operator's manual,
- ❑ never operate the mower when it is not in working order or has damaged safety guards,
- ❑ never get your hands and legs close to rotating parts of the mower,
- ❑ during repair and maintenance of the mower, always comply with descriptions included in operator's manual. Always do these activities when the tractor's drive is off,
- ❑ never operate the mower under influence of alcohol, drugs, or strong medicine that impair your attention,
- ❑ do not wear clothes or jewelry that are too loose or too tight. Too loose clothing or jewelry may be pulled in by the rotating parts of the mower,
- ❑ the mower should not be operated by children or by handicapped people,



WARNING:

If the instructions and prohibitions are not adhered to there remains residual risk.

5. Residual risk assessment

Residual risk occurs from not complying with the instructions and safety precautions. Such risk can be minimized by doing the following:

- ❑ thorough familiarizing yourself with operator's manual,
- ❑ allow no persons on the machine when operating,
- ❑ allow no persons within the mower operation range,
- ❑ adjust, maintain and lubricate the machine with the engine off,
- ❑ only skilled persons should perform repairs of the machine,
- ❑ children and strangers must keep away when the machine is operating,



When the risk of exposure to noise cannot be avoided or eliminated by any protective means or organization of work, the employer (farmer) must:

- 1) provide the operator with individual means of noise protection if the noise level in work place exceeds 80 dB.
- 2) provide the operator with individual means of noise protection and supervise the correctness of its usage, if the noise level in work place reaches or exceeds 85 dB.

4.7. Safety labels and their meaning

Safety labels are critical to safe use of this mower. They must be read, understood and followed.

Also, be sure that:

- ❑ All warning decals are clean and legible
- ❑ All lost or damaged decals are replaced by ordering new decals from your dealer or supplier
- ❑ All persons using this mower have read the section of this manual explaining the meanings of these labels

All spare part used for repair of the mower should have all safety labels provided by the manufacturer.



N-1

Be extremely careful when PTO shaft is rotating



N-2

Caution: cutting knives. Approach during operation is forbidden



N-3

Read the operator's manual before putting the mower into operation



N-4

While making repairs the machine must be stopped



N-5

Caution: belt transmission, be extremely careful



N-6

Caution: pulling-in parts



N-7

Operating is forbidden when any person is within the danger area of 170'



N-9

Caution: rotor

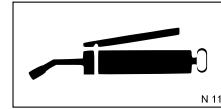

N-11

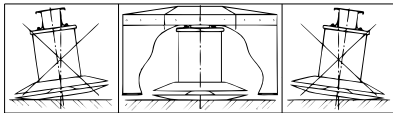

N-13

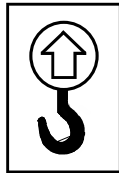

N-40

Signs indicating transport holders

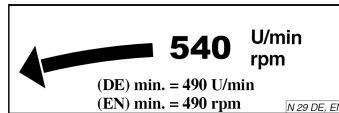

N-29



N-49

Never stand near tractor's 3-point linkage while steering tractor's lift



N-33



N-50

Do not stay in the swinging area of mower's parts



N-52

Wear protective gloves



N-55



N-167

Do not go onto safety brackets and guards



N-168

Do not touch the machine before the rotating parts have not come to a complete standstill

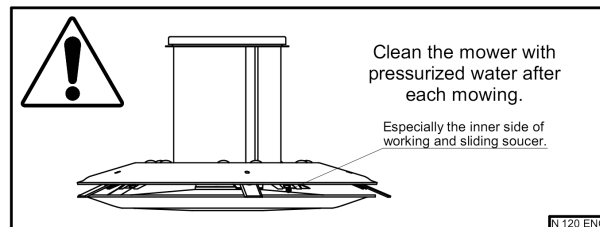

N-120

CLEAN THE MOWER EACH DAY AFTER WORKING
ESPECIALLY THE INSIDE OF WORKING SAUCER (KNIFE HOLDERS, KNIVES) AND SLIDING SAUCER, BECAUSE GRASS WITH MUD MAY DAMAGE BEARINGS IN SLIDING SAUCER HUB OR IN VERTICAL DRIVE SHAFT.

N-107

WORKING WITHOUT GUARDS IS FORBIDDEN
DANGER OF THE STONES, ETC. BEING THROWN OUT

P-2

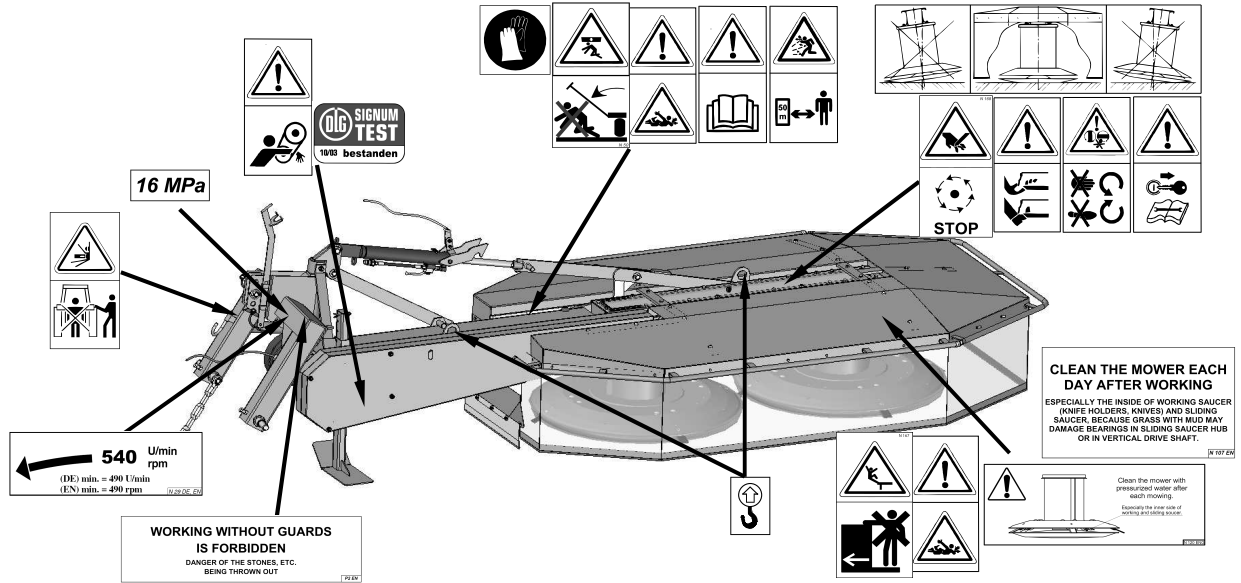

Fig. 7a. Warning decals placed on the mower (Z 010, Z 010/1, Z 010/2)

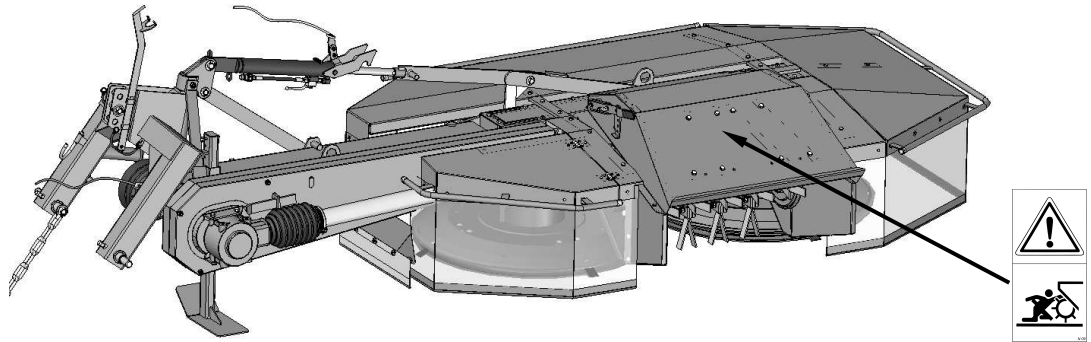

Fig. 7b. Warning decals placed on the mower with swath conditioner Z 010/4 a.o.

4.8. Design and operation of safety breakaway device

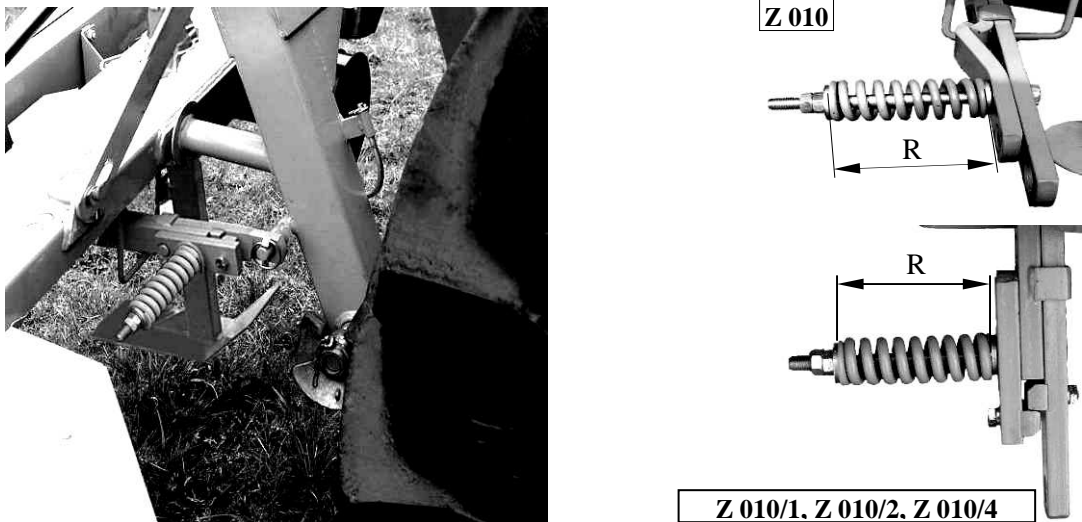

Fig. 8. Safety breakaway device

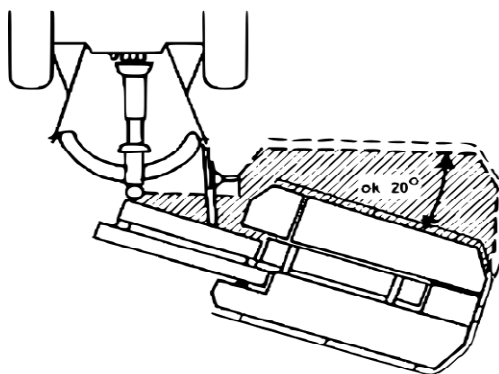

Fig. 9. The mower is retracted when the safety device operates

Safety device's spring (**Fig. 8**) is adjustable by changing the force needed to make safety device work. In the event of hitting an immovable obstacle one of the safety device flat bars slides out and disengages the safety device. After that the mower folds back about 20 degrees (**Fig. 9**). The operator has time to shut off the tractor and protect the mower.

Tab. 3. Recommended length of safety device spring

Model	Dimension „R” of safety device spring [ft in]
Z 010 – 1.65 m	5.51"
Z 010/1 – 1.85 m	5.31"
Z 010/2 – 2.10 m	5.31"
Z 010/4 – 2.10 m	4.05"

If the safety device breaks away too easily, tighten the spring by approximately 0.04 – 0.08". DO NOT tighten too much, because you may prevent the safety device from working and damage the mower.

NOTE:

Do not move the mower's safety breakaway device from transport to working position and vice versa with the mower's cutting unit lifted up, the engine operating or the tractor's neutral gear engaged.

- a) In order to switch the mower's safety breakaway device from transport to working position, do the following:
- lower the mower's cutting unit onto the ground,
 - disengage the transport lock (**Fig. 10a-b**),
 - turn the tractor's front wheels maximum left (**Fig. 13**) and drive backwards until the mower's catch bumper contacts the middle beam,
 - turn off the tractor's engine and engage neutral gear or hand-brake, so that the tractor is secured against moving,
 - push the mower's safety breakaway device onto pin on the catch and protect with cotter (**Fig. 11a-b**).

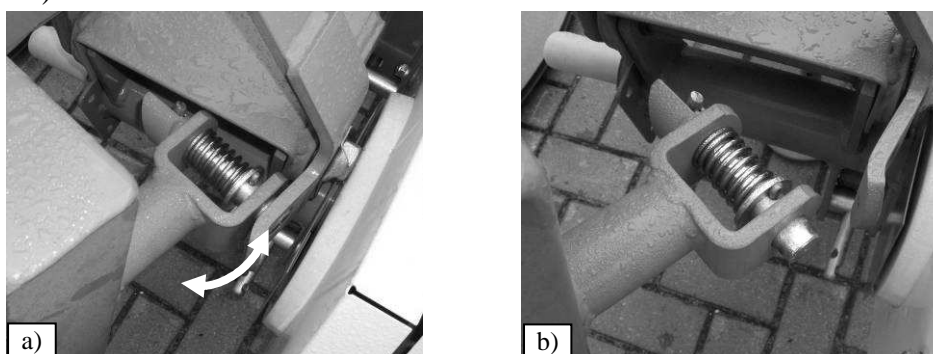

Fig. 10. Mower's transport lock a) transport position, b) working position

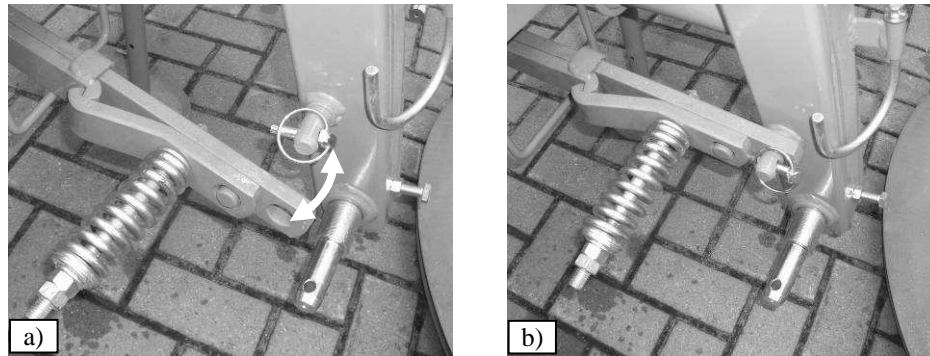

Fig. 11. Safety breakaway device a) transport position, b) working position

- b) In order to move the mower's safety breakaway device from working to transport position, do the following:
- ❑ lower the mower's cutting unit onto the ground,
 - ❑ turn off the tractor's engine and engage neutral gear or hand-brake, so the tractor is secured against moving,
 - ❑ remove the cotter and take the safety breakaway device off from the cotter (**Fig. 11b-a**),
 - ❑ start the tractor's engine, turn the wheels maximum left and drive the tractor forward until the transport lock is engaged (**Fig. 10b-a**).

5. OPERATION

WARNING:

Before beginning to use this machine, do the following:



- Read manual, especially safety precautions in section 4.
- Make sure you are familiar with all controls and functions.
- Make sure all safety devices are in place and working. Fix or replace if not working or damaged.
- Replace protective cover if damaged.

5.1. Attaching the mower to the tractor



WARNING:

- Only hitch and unhitch machine on a flat surface with compact dirt.
- Keep everyone away from area between mower and tractor.
- Be careful near link road zone of tractor's rear power lift. Contains sharp parts.

The mower is connected to the tractor's 3-point-linkage.

Once the mower is suspended adjust the setting on an even ground with adjustment screw **S** (**Fig. 12**) and hangers **W** of the tractor's lower links. The mower's drums should be parallel to the ground (hence this is a condition for a sustained stubble). Hangers **W** of the tractor's lower links should be placed on pins **A** of the mower's 3-point linkage frame.

After the mower has been attached to tractor, check balance and steerability of tractor-mower set. To do it, weigh the set and after that drive on the scales with only front axis of the tractor (the mower must be in transport position – lifted upwards). If the pressure on the front axis is at least 20 % of the whole set's pressure, it means the set is stable. If not, front axis should be balanced.

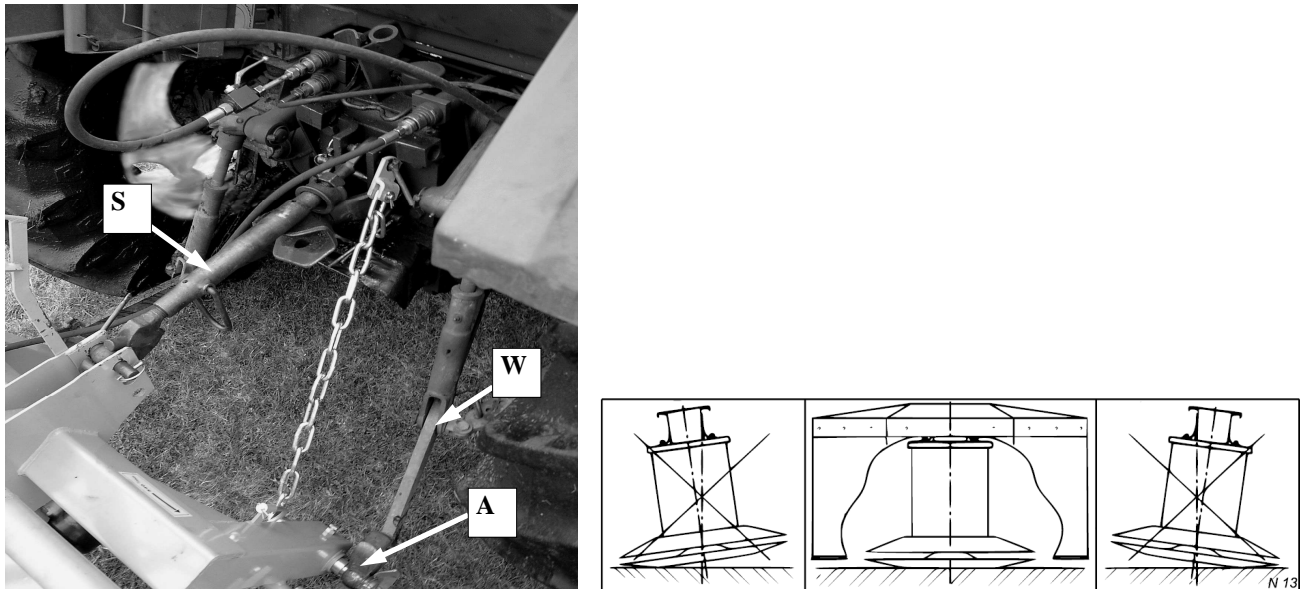

Fig. 12. Attaching the mower to the tractor

5.2. Preparing the mower for transport

NOTE

Moving the mower from working position to transport position and vice versa may only take place on an even and stable ground. Before approaching any works make sure whether there are no unauthorized persons exposed to the risk of crushing.

5.2.1. Standard mower design

In order to move the mower to the transport position, do the following:

- ❑ attach the mower on tractor's links,
- ❑ position the 3-point linkage with beam along the tractor's axis (Fig. 13a),
- ❑ adjust the mower with top link S (Fig. 12), if needed,
- ❑ disconnect the PTO shaft,
- ❑ set pawl Z (Fig. 22) in transport position.

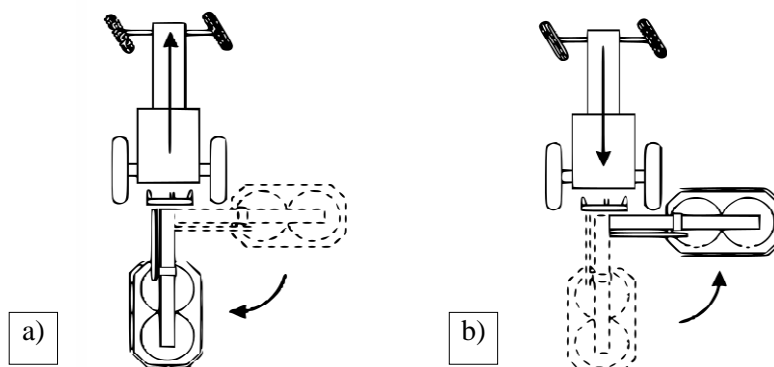

Fig. 13. Mower positions: a) transport position; b) working position



WARNING

Once the machine is set in transport position, check whether mechanical locking pawls are properly locked on pins.

5.2.2. Mower design with hydraulic lifting (optional equipment)

In order to put the mower to the transport position, do the following:

- ❑ connect the hydraulic hose for lifting the mower to tractor hydraulic unit,
- ❑ lift the mower with tractor's hydraulic lift until the lower lift pins of the mower's linkage frame are raised about 1'8" above the ground,
- ❑ use the tractor's hydraulic lever to pressurise the hydraulic cylinder on the mower and lift the cutting unit of the machine to the vertical position,



Fig. 14a. Side transport position



Fig. 14b. Rear transport position



CAUTION:

During transport the shut-off valve of mower hydraulic lift should always be closed – the valve lever in position **Z** (**Fig. 16**). This protects the mower against accidental falling if hydraulic unit failure occurs.

- ❑ to prevent the mower from falling down close the shut-off valve (**Fig. 16**) on the hydraulic cylinder (**Fig. 15**),
- ❑ in the side transport position (**Fig. 14a**) the PTO shaft can remain connected. In the rear transport position (**Fig. 14b**) disconnect the PTO shaft.

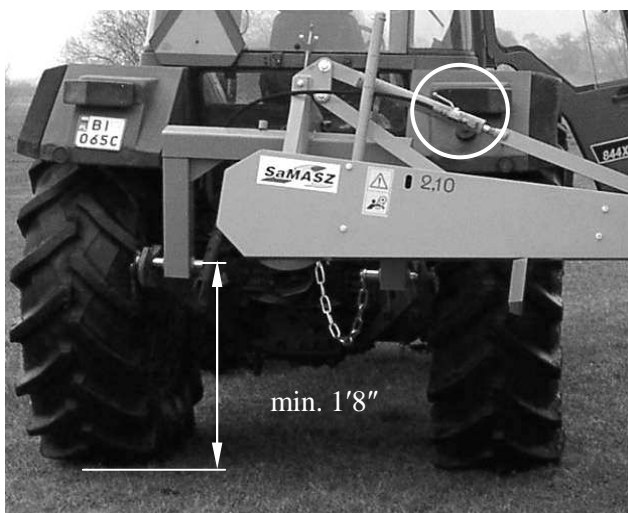

Fig. 15. Mower raised to transport position

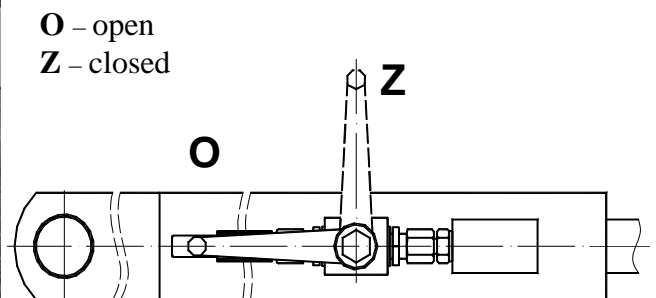

Fig. 16. Shut-off valve positions

In order to prepare the mower for transport and meet safety precautions, do the following:

- ❑ when lifting or lowering the mower check carefully the area around the tractor and machine,
- ❑ before lifting the machine to transport position set the machine while keeping the tractor's linkage parallel to the ground.



Fig. 17. Mechanical lock of hydraulic lifting function

5.2.3. Mechanical lock of hydraulic lifting

Mechanical lock is placed on hydraulic lifting cylinder to prevent accidental mower's falling when in transport position.

The lock is made as a pawl which engages automatically when the mower is lifted to transport position. Before lowering the machine to transport position disengage the pawl by pulling the line attached (**Fig. 17**).

5.3. Preparing the mower for transport on public roads



WARNING:

Legal requirements for transport on public roads may differ from state to state. Check your location's requirements and comply.

To comply with safety precautions concerning transport on the public roads the mower should be equipped with the following devices:

- portable warning light plates, comprising two panels (not delivered as standard equipment), to be mounted on both sides of the mower's top guard in special holders. The rear panel comprises a warning plate with lights combined with red reflectors,



Fig. 18. SaMASZ mower in the transport position with warning plates

- warning triangle which can be mounted in holder on top mower guard.

5.4. Mounting PTO shaft

PTO shaft's end with overrunning clutch should be mounted on mower's side.

When connecting PTO shaft between tractor and mower make sure that external guard tube of the shaft is on the tractor's side. The PTO shaft plastic guards have to be secured by fastening their small chains to immovable parts of tractor and mower. The PTO shaft must operate at the lowest possible angle. This will ensure that both shaft and the machine last as long as possible.



CAUTION:

If need be, shorten the PTO shaft according to its operator's manual given by the shaft's manufacturer (Fig. 19).

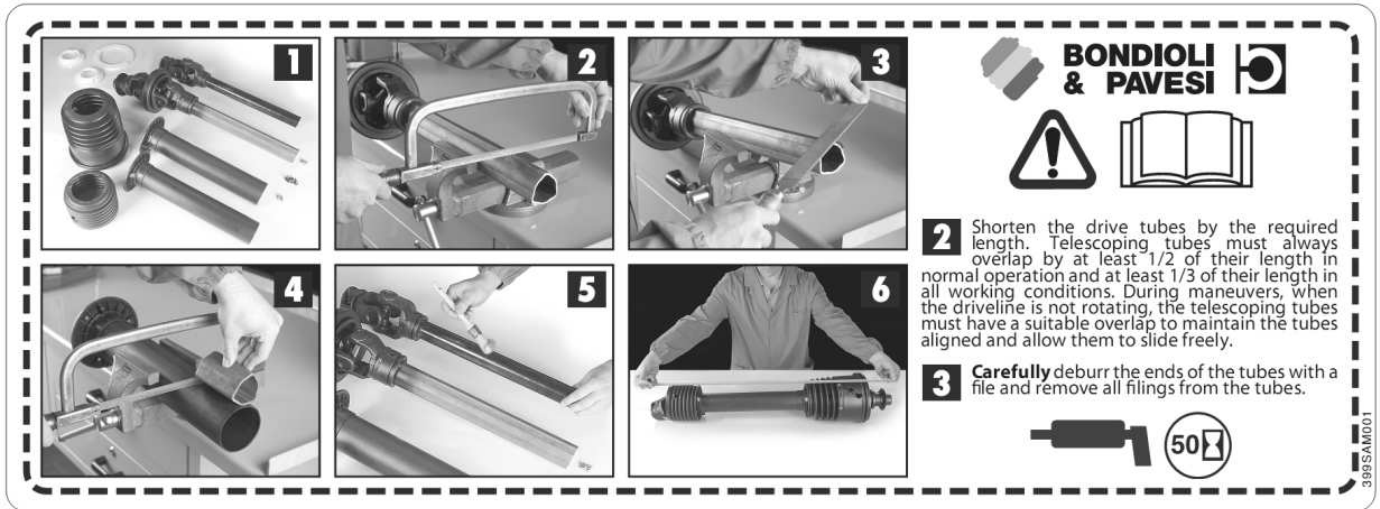

Fig. 19 Instruction of PTO shaft shortening



CAUTION:

Handle all parts with utmost care. Never place your hands or fingers between one part and the other. Wear safety clothes such as gloves, protective footwear and goggles. The operation of shortening must be carried out with the utmost care as the PTO shaft will have to be replaced if the telescopic shafts are shortened to an excessive extent.

NOTE:

The PTO shaft should be mounted only during operation time and disconnected from tractor PTO for transport and service.

NOTICE:

The manufacturer declines all liability for damage caused by an incorrectly fitted or used PTO shaft.



IMPORTANT:

Use only with PTO shafts as recommended by the manufacturer. Before the work begins, check the safety guards (in tractor, mower and PTO shaft) for their correct mounting and damage. Damaged or lost parts must be replaced with original ones only. Make sure that PTO shaft is properly mounted. Do not approach the rotating parts, as this may lead to serious injuries or even death. All service and repair operations must be performed only after the tractor's engine has been stopped and ignition key taken out, all rotating parts have come to the complete standstill and the cutting unit is on the ground. Before the operation begins, read operator's manuals of both the machine and the PTO shaft.



WARNING:

For Z 010/2 mower use shaft with right overrunning clutch only. See Tab. 2 and Fig. 4b. Use of a shaft with no clutch may cause serious damage to the mower and therefore void the warranty.

5.5. Adjusting conditioner shaft's position

Correct position of conditioner's shaft in relation to operating discs enables proper distribution of swath for further treatment. Therefore pay particular attention to the position of the conditioner's housing so that the constant distance of ~0.79" between flail ends and operating disc surface is maintained. For a dense and abundant grass the clearance should be increased to ~1.18" so as to prevent the conditioner from clogging. This distance is adjusted with spacers installed between the mower's frame and the conditioner's housing (**Fig. 20**).

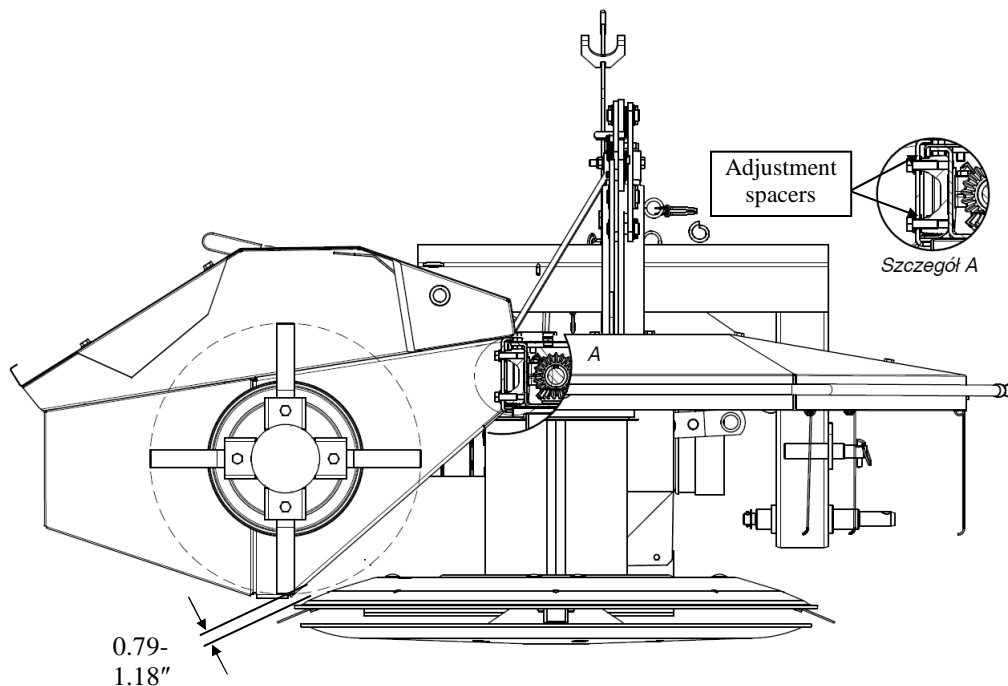

Fig. 20. Adjusting conditioner shaft's position

5.6. Replacing flails in conditioner's shaft

If flails are worn due to normal operation, they must be replaced. Before any operation, always check the condition of bolts mounting the flails as well as the condition of flails themselves.

NOTE:

When replacing conditioner's shaft always use a new bolt M12x55, z. Property Class 8.8 and a new self-locking nut M12, z. Property Class 8.8, **tightening torque 55 Nm.**

To disassemble the flail unscrew nut (M12 z. Property Class 8.8) with open wrench (19), taking both the bolt M12x55 z. Property Class 8.8 and the flail out. To mount new flail follow the steps in the opposite order (**Fig. 19**).

1. Bolt M12x55 z. Property Class 8.8
2. Flat washer Ø12
3. Self-locking nut M12 z. Property Class 8
4. Ram
5. Flail's rubber insert

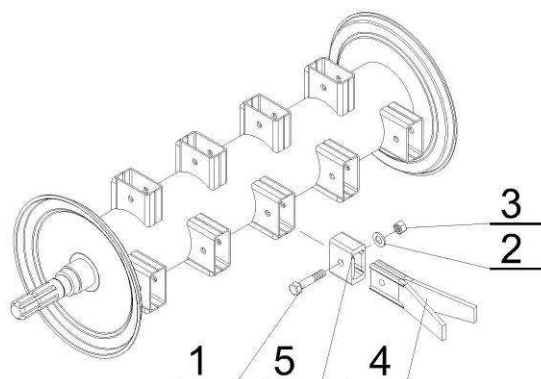

Fig. 21. Replacing the conditioner's shaft

5.7. Operation

5.7.1. Standard mower design

- ❑ lower the mower until the sliding discs have come to contact with the ground,
- ❑ set the safety breakaway device in working position (according to item 4.8a),
- ❑ open the locking pawl “Z” (**Fig. 20b**) to allow pin “T” to move in the slot in lifting bar “N”. This enable the mower to follow the ground,
- ❑ connect PTO shaft to both the tractor and the mower,
- ❑ slowly engage the PTO clutch and wait until the cutting unit reaches its rated speed,
- ❑ engage tractor’s gear and drive slowly into the grass - field.

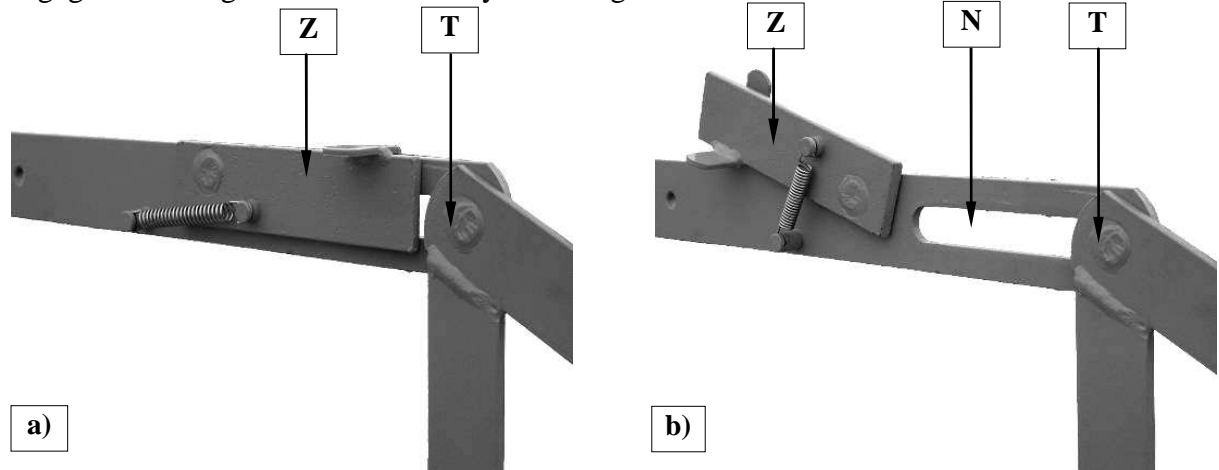

Fig. 22. Positions of locking pawl “Z”: a) transport, b) working

5.7.2. Mower design with hydraulic lifting (optional equipment)

- ❑ Set the safety breakaway device in working position (according to item 4.8a),
- ❑ open the shut-off valve on the hydraulic cylinder (**Fig. 16**),
- ❑ move the cutting unit into the working position,
- ❑ lower the mower until the sliding discs have come into contact with the ground,
- ❑ connect PTO shaft to both the tractor and the mower,
- ❑ slowly engage PTO clutch and wait until the cutting unit reaches its rated speed,
- ❑ engage tractor’s gear and drive slowly into the grass - field.



Fig. 23. Working position of SaMASZ rear drum mower

5.8. Dismounting mower from tractor



WARNING:

When dismounting, make sure there is no person in between the mower and the tractor.

To dismount the mower from the tractor:

- ❑ turn cutterbar's drive off,
- ❑ place the mower on an even, paved ground; then lower and check whether the mower is properly secured against falling,
- ❑ turn the tractor's engine off and take ignition key out,
- ❑ dismount the PTO shaft and place it on a PTO shaft holder which is standard-delivered with the mower,
- ❑ detach tractor's upper link and lower strands from mower's linkage.

6. MOUNTING AND ADJUSTMENTS

6.1. Mounting and timing of the knives

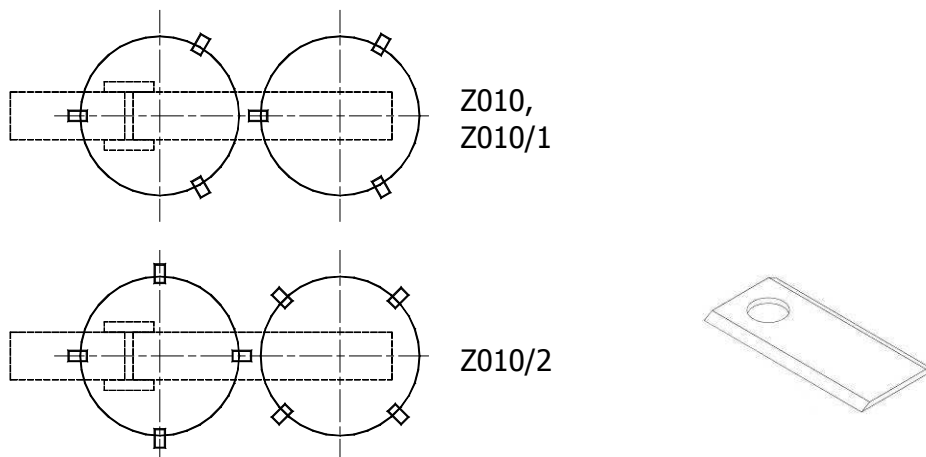

Fig. 24. Timing of the knives on the mowing discs

NOTE:

Direct the cutting edges of the new knives towards the ground.

6.2. Replacing the knives

NOTE:

Use knives recommended by the manufacturer only.

When replacing the knives use a special lever to tilt the knife holder (**Fig. 25**). New knives should be mounted with their edges up. In the case of used knives, if one cutting edge is worn, remove the knives onto the other drum.

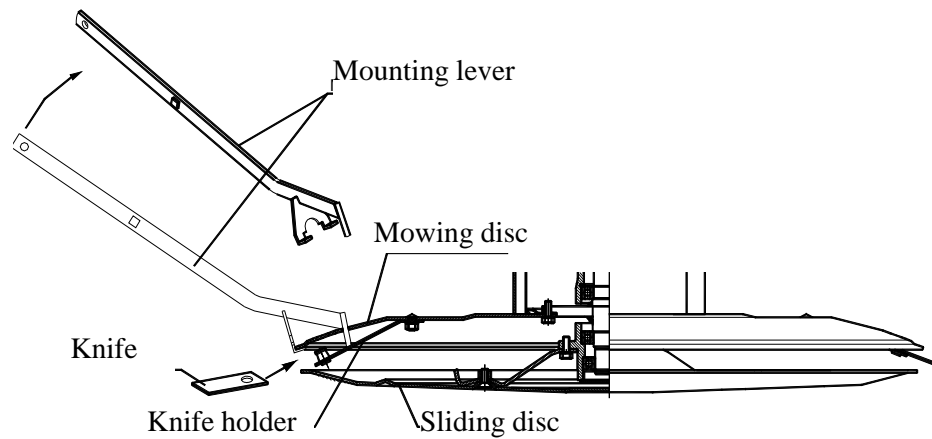

Fig. 25. Mounting and replacing the knives

NOTE:

When replacing knives the tractor's engine should be stopped and ignition key taken out. The PTO shaft between the mower and the tractor must be disconnected.

6.3. Adjusting the cutting unit

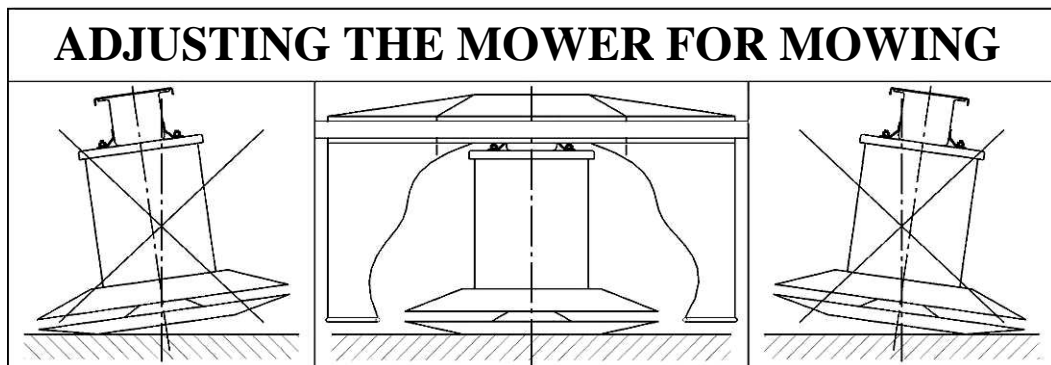

Fig. 26. Adjusting the drums level with the ground

6.4. Adjusting the cutting height

The mower has a factory-set cutting height of 2.28" - 2.36". The cutting height can be adjusted by removing a distance ring (spacer), as shown in (Fig. 27). Removing the spacer results in a new cutting height of 1.97" - 2.05". By putting one additional spacer over the support disc cutting height of 2.60" - 2.68" is achieved. Additional spacers can be ordered (optional extra equipment).

NOTE:

When mounting additional distance rings use longer bolts - M10x35 (Z 010, Z 010/1) or M10x40 (Z 010/2, Z 010/4) and tighten them with a torque of 55 Nm.

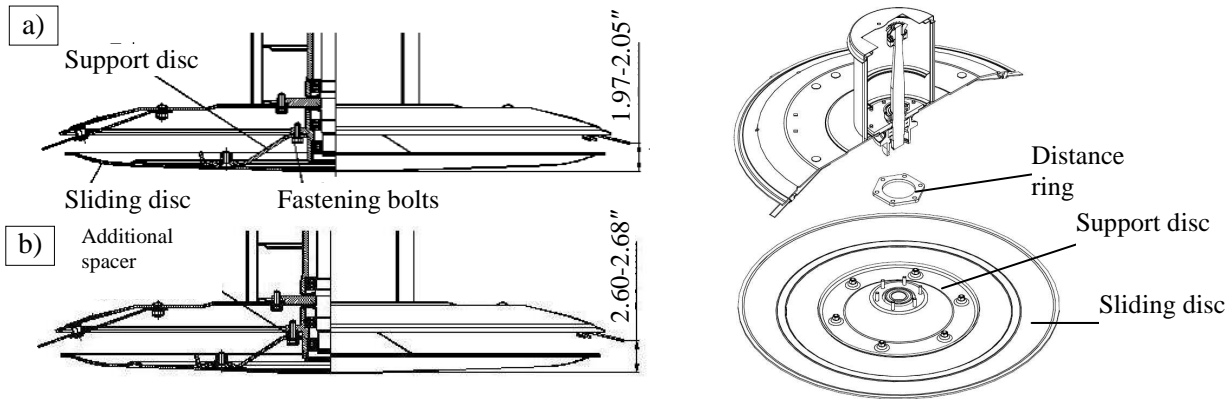

Fig. 27. Adjusting the cutting height by fitting or removing the distance ring

6.5. 3-point linkage support chain

(Model Z 010/2)

Support chain (Fig. 28) is used to ensure 3-point linkage frame of the mower is always at the same height, to set the mowing unit parallel to the ground and to relieve the hydraulic lift of the tractor. If the cutting unit is not set parallel to the ground, the bearings of sliding discs will be subject to premature wear.

When connecting the mower to the tractor, the hanger plate "A" of the support chain should be disconnected from chain and put on the pin "B" of top link. Then the mower should be lifted with hydraulic lift about 1'4" up (Fig. 23). The support chain is then connected to the hanger plate "A" so that is tensioned when the mower is in the working position.

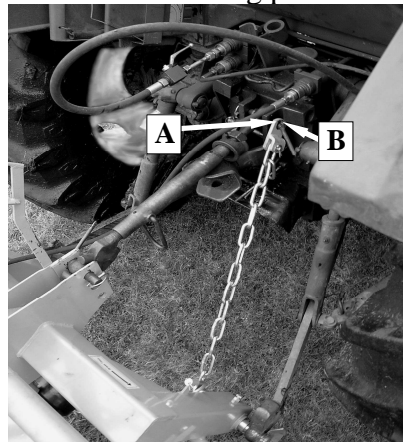

Fig. 28. 3-point linkage support chain

6.6. Maintenance and service

6.6.1. Checking the knives and knife holders

All knives should have the same lengths and weights. Always check mower before starting work for damaged, missing and/or worn knives. Replace them, if necessary, only in sets. Knife holders should not be deformed, and knife base on which the knife is mounted cannot be worn more than 50% of its cross-section (Fig. 29). If the base is excessively worn or holder's sides are deformed or worn, they should be replaced. Check the bases also for their condition and riveting. If the riveting is not tight, the holder should be replaced.



NOTE:

Before any work always check the condition of knives and holders. Damaged or worn elements pose danger of throwing objects and create hazard to health and life.

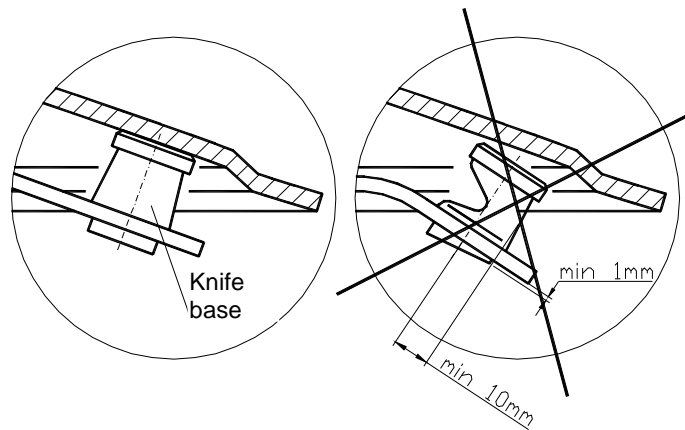

Fig. 29. Permissible wear of knife holders

6.6.2. Checking V-belts tension

Check the V-belt tension. Their deflection under finger pressure must not exceed 1.18". V-belts are tensioned with spring tensioner (**Fig. 30**) equipped with checking plate (1). Distance "A" between plate tip and holder should be 0 – 0.12". If the gap is wider the V-belts will be slacken.

When any of the belts are damaged, replace the complete set.

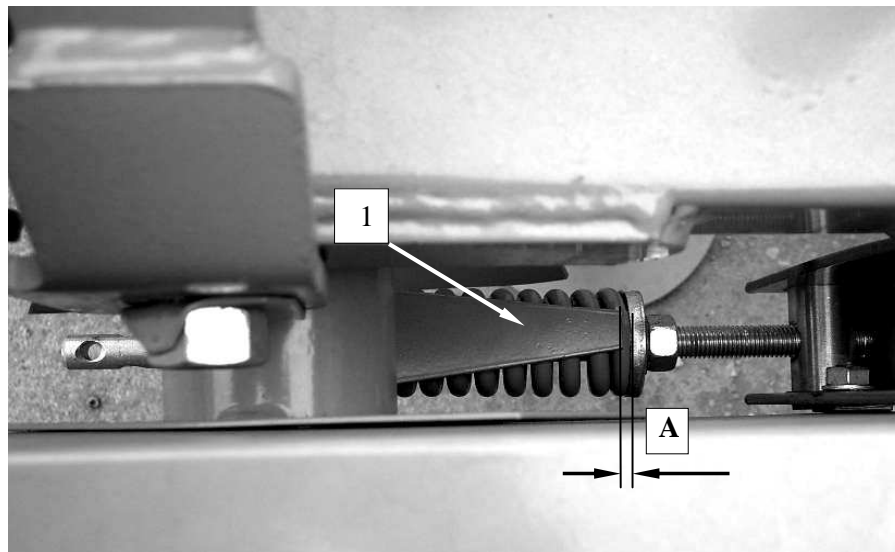

Fig. 30. Spring V-belts tensioner, 1 – checking plate. Check dimension "A" should be 0 – 0.12"

6.6.3. Daily maintenance

When you finish each day of operation carry out the following maintenance:

- ❑ check all visible parts and components and their connections; tighten all loose bolts and nuts and replace all damaged and/or worn parts with new original ones,
- ❑ clean the mower, especially between discs and cutting unit, because grass with mud may damage bearings in disc module,
- ❑ remove grass and mud,
- ❑ check the cutting unit,
- ❑ grease PTO shaft tubes with STP grease,
- ❑ if necessary, lubricate the parts and components according to lubrication instructions (chapter 7).

Parts which may cause risk to operator's health and safety are as follows: damaged discs, missing or damaged safety covers, worn or damaged hydraulic hoses, PTO shaft guides, worn knives and knife holder pins.

6.6.4. After-season maintenance and storing of machine

At the end of mowing season the following shall be performed:

- ❑ lower the mower's cutting unit onto the ground,
- ❑ take the PTO shaft extension out of the tractor rpm or dismount the complete PTO shaft and install it into corresponding holder at the 3-point linkage frame,
- ❑ unmount hydraulic and electrical hoses from the tractor and hang them onto corresponding holders on the 3-point linkage frame,
- ❑ unmount the mower from the tractor (reverse procedure as in case of attaching the mower to the tractor item 5.1), and then drive the tractor away.

Mower should be stored in standstill position, so it is supported onto supporting leg and the cutting unit. It is recommended to store the set on paved ground, preferably in roofed places, inaccessible to unauthorized personnel or animals.

If the machine is stored for a long period of time before first operation, its technical condition should be examined and special attention should be paid to the hydraulics and the drive. Paint the area where the paint is missing, hydraulic hoses checked and lubricated.

Additionally:

- ❑ remove any traces of rust and paint the area,
- ❑ check the oil level in the angle drives and the cutting unit (Section 7). If leaks are discovered, they should be repaired immediately and lost oil replaced. If water in oil is discovered, immediately change the oil as it could cause corrosion of internal mechanisms such as gear wheels, bearings, or shafts, and cause breakdowns,
- ❑ periodically inspect the mower and lubricate moving parts in order to protect them from corrosion which adversely affects the proper operation of the mower,
- ❑ check hydraulic hoses regularly. Replace any damaged or old hoses. In any case, you should replace hoses that have been in use more than 5 years from the date of their manufacture printed on the hose.

6.6.5. Restarting the machine after repairs or longer storing periods

- ❑ Make sure that all nuts and screws are tightened with correct torque.
- ❑ Make sure that all guards are in place.
- ❑ After the storing period lubricate all parts of machine.

Tab. 5. Torque values for bolts

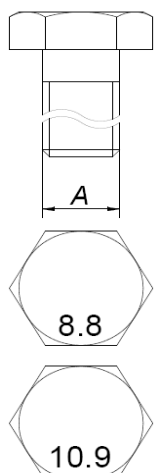
A Thread	6.8	8.8	10.9	12.9	
	M _A [Nm]				
M4	2.2	3.0	4.4	5.1	
M5	4.5	5.9	8.7	10	
M6	7.6	10	15	18	
M8	18	25	36	43	
M10	37	49	72	84	
M12	64	85	125	145	
M14	100	135	200	235	
M16	160	210	310	365	
M18	220	300	430	500	
M20	310	425	610	710	
M22	425	580	820	960	
M24	535	730	1050	1220	

7. LUBRICATION INSTRUCTION

7.1. Gear trough (gearbox)

The oil level should be checked regularly through the venting opening on the gear trough. The oil level should be 0.59 – 0.79" above the bottom of the trough, when the frame is level. Oil capacities in the gear box are as follows:

- Z 010 – 2.5 L,
- Z 010/1 – 3.5 L,
- Z 010/2 – 4.5 L.

If the oil level is low, please check and eliminate any leaks and fill up to the oil level required.

7.2. Mower's gearbox and conditioner's intersecting axis gear

The oil level should be checked regularly through the venting opening on the gear box. The oil level should be 0.59 – 1.18" above the bottom. Oil capacity in the gear boxes for mower Z 010/4 – 4.5 L.

The oil capacity in conditioner's gear should be ~ 0.3 L. Intersecting axis gear of conditioner's drive should be filled with gear oil through filler, located in the gear's cover.

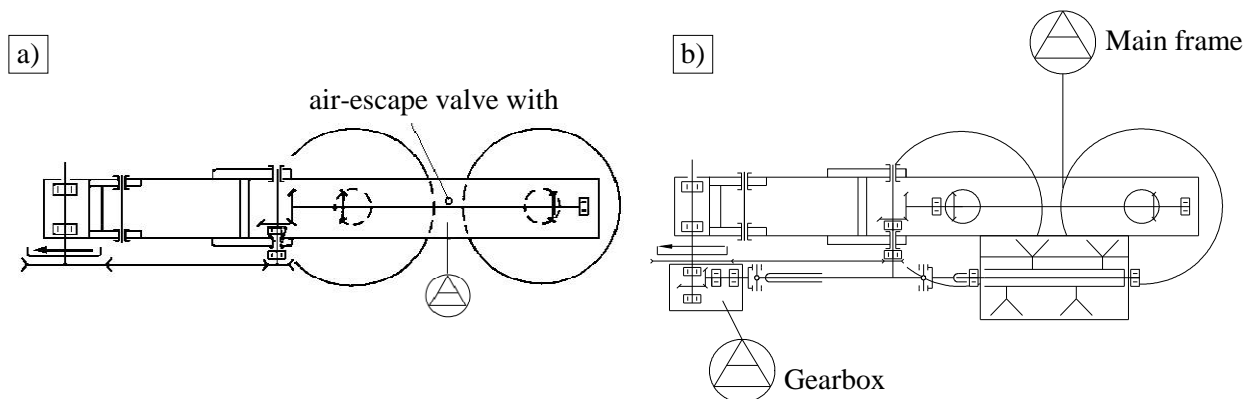

Fig. 31. Lubrication points a) mowers Z 010; Z 010/1; Z 010/2, b) mower Z 010/4

Tab. 6. Lubricating mowers

Symbol	Oil type	Lubrication frequency
	Gear oil 80W/90	Once every 3 seasons (if working intensively)

7.3. Risks present when lubricating

- If risk of splashing is present, make sure to wear protective eyewear with side guards.
- When lubricating protect eyes and skin against contact with the substance. Therefore use adequate protective wear with long sleeves and protective footwear. Also use protective gloves. In case of a contact with skin, immediately wash the infected area with plenty of soap water.
- Do not allow the product to contaminate water outlets, water courses and soils.
- In case of an unintentional release to the environment plug the leak, limit the spillage, and then collect the oil with non-flammable absorbent material (e.g. sand).

- The product is flammable. In case of fire, use adequate fire-extinguishing means (e.g. foam, water mist, extinguishing powders). Do not use water jets.
- Used product should be disposed of in accordance with relevant regulations. If disposed of improperly, the used oil poses danger to the environment.

8. DEFECTS AND THEIR REPAIRS

Defect	Reason	Repair	
Mower stops working (partly)– leaves stripes of uncut grass between the discs	Lack of knives	Put on knives	
	Worn knives	Replace knives	
	Space between the knife and knife holder filled with mud, grass, etc.	Remove dirt (wash with water under pressure)	
	Sliding V-belts	Too low spring tension – Adjust the spring acc. to instructions	
		Worn V-belts – Replace V-belts	
	Damaged tractor's PTO No power transmission	Repair PTO shaft	
	Stones between moving parts	Stop and remove	
	Lying grass	The inclination - the angle zero	
Mower with either tine or roller conditioner may mow improperly in case of very short grass or after rain			
Safety device is working often without clear reason	Insufficient spring tension	Adjust spring tension according to operator's manual	
	Worn elements of safety device	Replace the safety device	
The mower will not fold up	Damaged or dirty hydraulic connections	Replace or clean hydraulic connections	
	Damaged tractor hydraulic system	Check for proper function of the tractor hydraulic system	
Leaking cylinder	Contaminated oil in the tractor hydraulics	Replace oil in the tractor hydraulics (recommended class of cleanliness of oil according to NAS 1638 is minimum 9-10). Provide brand new cylinder repair kit and replace worn gaskets	
Excessive vibration during work	Damaged PTO shaft	Check the condition of PTO shaft and if necessary replace	
Oil leak in gear	Not tight assembly	Examine tightness and check oil level.	

9. DISASSEMBLY AND WITHDRAWAL FROM USE

9.1. Scrapping

If the mower cannot be repaired anymore, it should be withdrawn from use.

To do so, oil from intersecting axis gear and cutterbar should be drained and delivered to a proper waste treatment company. Clean the mower parts, dismantle and dispose properly of all plastic parts. After that, the mower can be scrapped.

10. WARRANTY CARD

REAR DRUM MOWERS

Serial number
Date of manufacture
Manufacturer's stamp
QC signature

Date of purchase
Dealer's stamp
Dealer's signature

The product quality has been checked and meets the required standards and regulations and is permitted for use.

NOTE: A warranty card without the required information or with corrected or illegible information – **is invalid.**

11. WARRANTY TERMS

11.1. Warranty claims procedures

1. The manufacturer guarantees its products against faults in materials or production.
2. Warranty period is for two years from the date of sale to the purchaser, stated above.
3. Any repair which is subject to warranty should be carried out by an authorised SaMASZ dealer. Upon completion of the repair, the dealer must submit a warranty claim within 14 days.
4. Warranty claims regarding replacing of the product are considered if received within 14 days after it is completed by the manufacturer.
5. The following parts and situations are not covered by warranty:
 - a) **wearing parts: cutting plates, sliding skids, intersecting axis gears and parts inside the gearboxes, bushings and sliding elements, clutches, joints, knife holders, cutting knives, V-belts, sprockets, drive chain, conditioner's tines and rollers, roller conditioner's rubbers, bearings, rubber-metal fenders, safety curtains, conveyor's belts, swath guides rubbers, connective elements, etc.**
These repairs may be done only at purchaser's cost,

- b) **use for any other purpose than those described in the operator's manual,**
 - c) **operation on stony fields and results such as: damage of tine conditioner's shaft, discs, bending of cutting unit (stone with its diameter of 5.5" will not move between the discs and conditioner's shaft),**
 - d) **running into any obstacle,**
 - e) **too fast lowering of the cutting unit to the ground**
 - f) **transport and accidental damage.**
6. The Purchaser bears the costs of technical evaluation - when the manufacturer finds that a claimed product is free of defects and a technical report confirms that.
7. The manufacturer has the right to cancel a warranty in the following cases:
- a) **interference of the interior of the mower, changes of its mechanical design or intentional damages, bending parts of the mower and so on,**
 - b) **operating with only 1 knife on the disc or without disc cover plates,**
 - c) **damage caused by accidents, running into obstacles or other events, for which the warrantor is not responsible,**
 - d) **use of different knives - not original SaMASZ knives,**
 - e) **negligent maintenance,**
 - f) **use of non-genuine spare or replacement parts that are not specifically designed for the model in question,**
 - g) **lack of needed records in the warranty card or filling in the warranty card independently,**
 - h) **use of the mower not in accordance with operator's manual or for incorrect purpose, or use of the machine by untrained persons**
8. Manufacturer can break the service agreement with immediate effect when the user does not pay the invoice according to that agreement in a timely manner and the delay in payment is longer than 30 days from maturity date. Breaking the service agreement caused by the user also invalidates the warranty.

NOTE:

Please ask your dealer to complete and return the warranty card, otherwise you may lose your warranty rights.

The warranty card is valid only when it contains the following information: address, date and place of purchase, mower type and invoice number.

11.2. Warranty repairs record

Repair description and changed spare parts:

Date, stamp and signature of repair shop.

Date, stamp and signature of repair shop.

Date, stamp and signature of repair shop.